



Edition : 1.0  
Date: (11/24)

## Instruction Manual

# MOBILE WORK BENCH MWB-1275

Order Code: (A401)

Before assembling, please pay attention to the following points in priority:

1. Confirm the names and quantity of the components.
2. Assemble it on the soft floor such as smooth carpet and flannel blanket.
3. Suggest wearing gloves to ensure that it can be assembled safely, and be certain that it will be done by more than two persons.
4. Tighten all screws before use.
5. Do not use it on an inclined or uneven surface.

## PARTS LIST

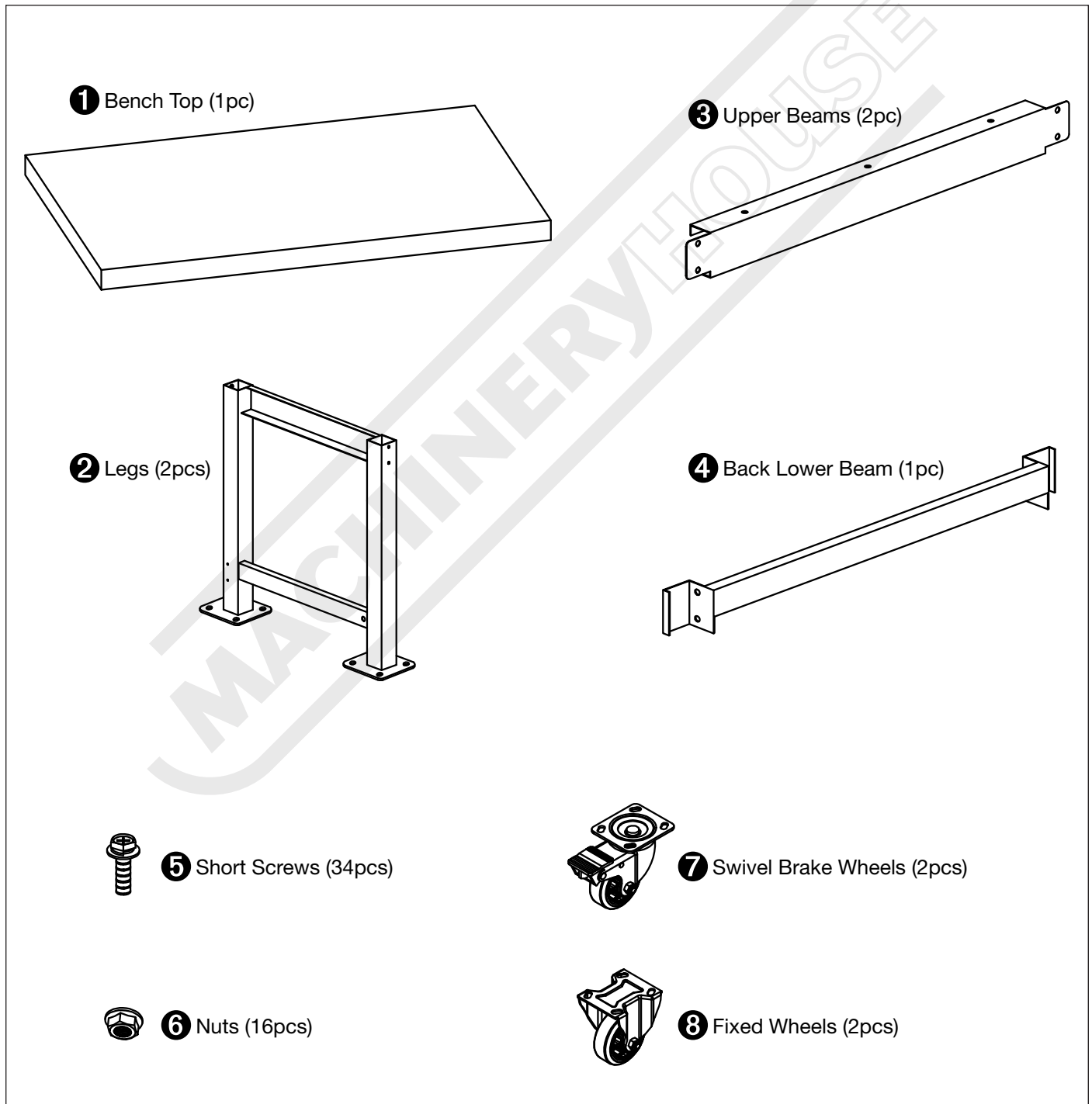

## ASSEMBLY

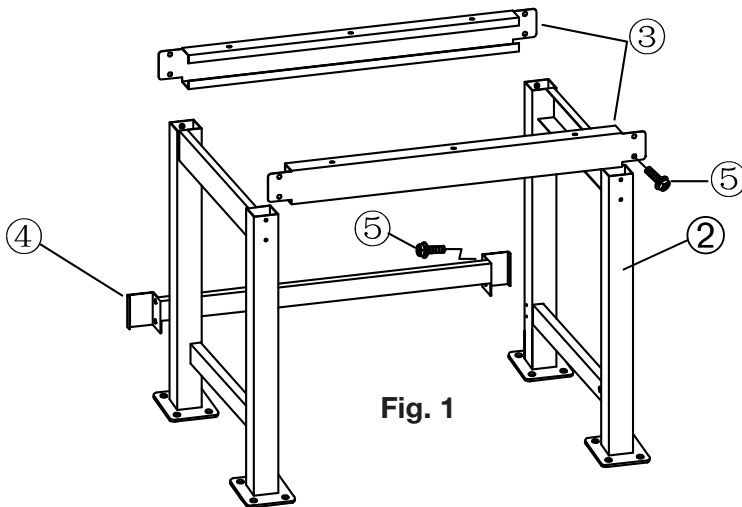

Fig. 1

**Step 1:** As shown in the drawing, put the two legs (2) upright and opposite to each other, and then connect the upper beams (3) to the legs (2) with short screws (5). As shown in (Fig.1).

**Step 2:** Insert the back lower beam (4) into the back legs from the back side, its connecting hole aligned with the lower connecting holes of the legs, and fit it with the short screws (5). As shown in (Fig.1).

**Step 3:** Place the top (1) upside down, then put the assembled bench frame on top (also upside down). As shown in (Fig.2).

**Step 4:** Align the assembled bench to the top (1) and connect with short screws (5). Ensure all parts are tightly fixed together. As shown in (Fig. 2).

**Step 5:** Install 2 swivel brake wheels (7) to left side and 2 fixed wheels (8) to right side on feet of legs (2) using short screws (5) and nuts (6). As shown in (Fig. 3).

**Step 6:** With the help of a second person turn the table back up the right way. As shown in (Fig. 4).

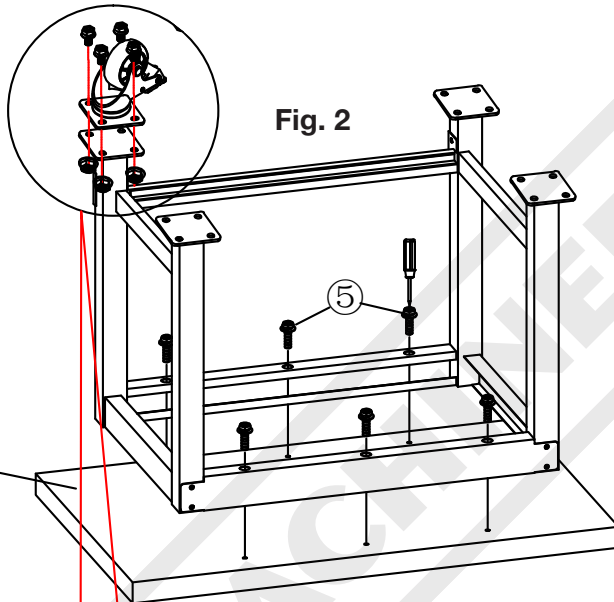

Fig. 2

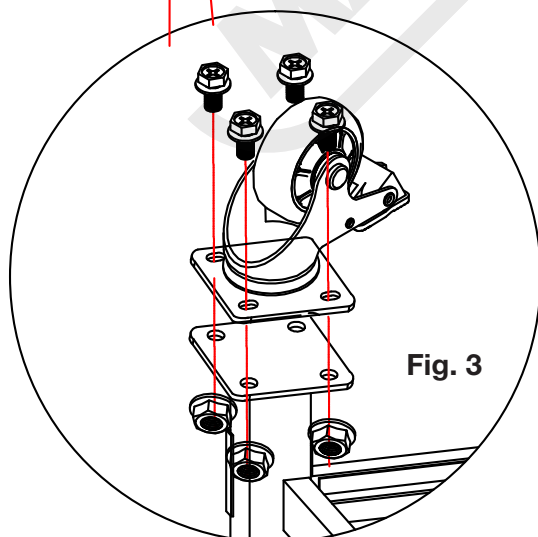

Fig. 3

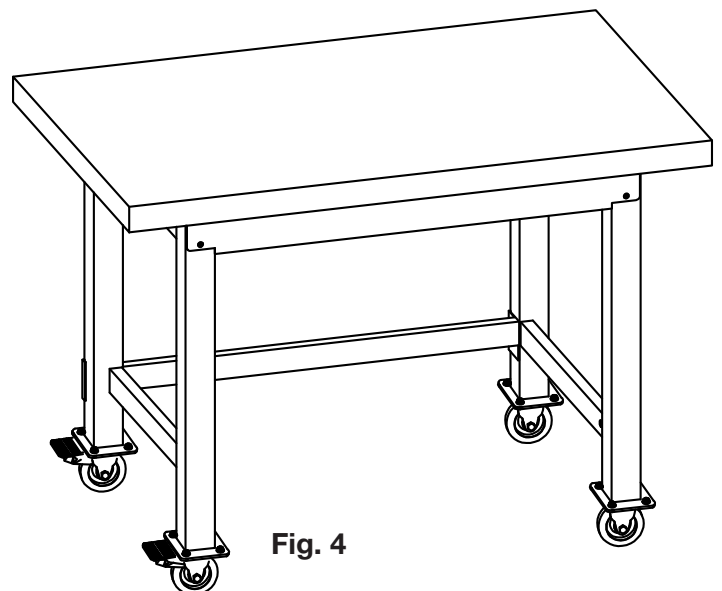

Fig. 4



### ENVIRONMENT PROTECTION

Recycle unwanted materials instead of disposing of them as waste. All tools, accessories and packaging should be sorted, taken to a recycling centre and disposed of in a manner which is compatible with the environment. When the product becomes completely unserviceable and requires disposal, drain any fluids (if applicable) into approved containers and dispose of the product and fluids according to local regulations.

Imported by

**HARE & FORBES**  
**MACHINERYHOUSE**

Australian Distributor

**Hare & Forbes**  
**Machineryhouse**  
Sydney - Melbourne  
Adelaide - Brisbane - Perth

Ph: 1300 202 200  
[www.machineryhouse.com.au](http://www.machineryhouse.com.au)

**MACHINERYHOUSE**

New Zealand Distributor

**Machineryhouse**  
Auckland  
Christchurch

Ph: 0800 142 326  
[www.machineryhouse.co.nz](http://www.machineryhouse.co.nz)